

## Junction Box for Digital Load Cells (DLC)

### FEATURES

- Available for a maximum of 4 and 8 load cells
- Stainless steel construction
- IEC529 enclosure Class IP66
- Integrated surge protection board
- Protects against voltages of up to 20 kV
- Protects against currents of up to 10 kA

### APPLICATIONS

- Digital weighbridge
- Digital platform scales
- Any systems that use digital load cells

### DESCRIPTION

These junction boxes have been designed to ease connection of digital load cell (DLC) systems. There are two variants, one supporting up to 4 digital load cells (SJB4), the other up to 8 digital load cells (SJB8).



The integrated surge protection protects digital load cells against damage from transient over-voltages or high impulse currents on field cabling. Surges such as these can be caused by nearby lightning strikes, power supply faults and heavy electrical load switching.

### CONFIGURATIONS

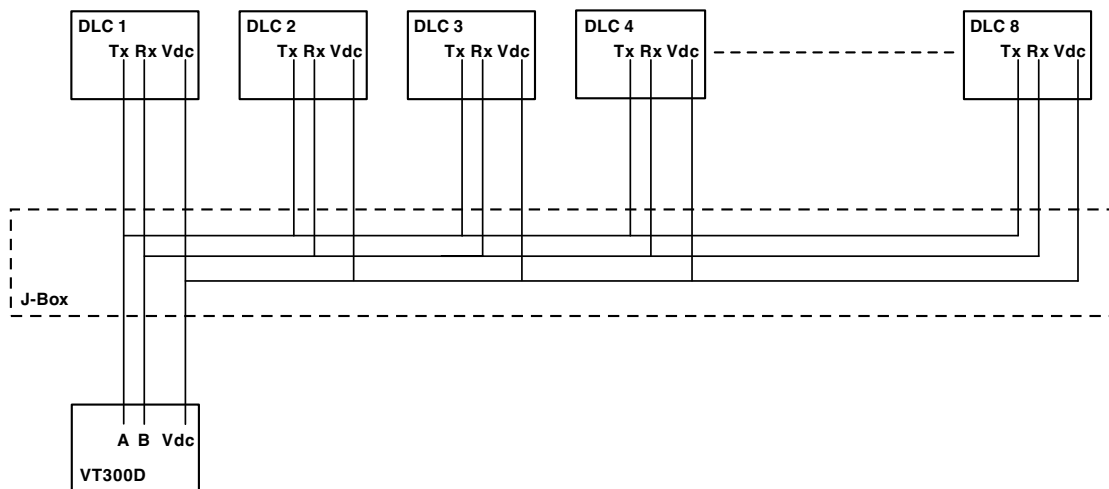

## Junction Box for Digital Load Cells (DLC)

SPECIFICATIONS			
PARAMETER		VALUE	UNIT
Max. number of load cells	SJB-4	4	
	SJB-8	8	
Types of DLC cables		2 or 3 times twisted pair	
Terminating resistors		2 x 120	$\Omega$
Operating temperature range		-40 to +70	$^{\circ}\text{C}$
Storage temperature range		-40 to +80	$^{\circ}\text{C}$
Humidity		0-85% non-condensing	
Data transmission type		RS485 / RS422	
Surge protection against voltages up to		20	kV
Surge protection against currents up to		10	kA
Sealing (to IEC 529 / EN 60.529)		IP66	
Material		Stainless steel	
Weight		1.3	kg
Cable glands: acceptable cable diameter		5-10	mm
Line to line protection		Yes	
Line to ground protection		Yes	
Line to ground let-through		<200	V
Screen to ground let-through		<400	V
Maximum current		600	mA
Inductance per line		110	$\mu\text{H}$
DC resistance per line		<2.1	$\Omega$

All specifications subject to change without notice.

### OUTLINE DIMENSIONS in millimeters

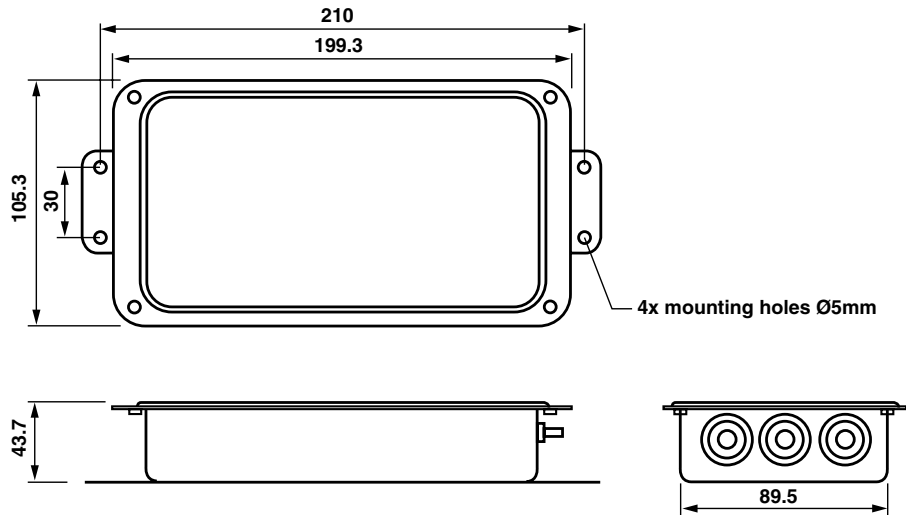

## Disclaimer

ALL PRODUCTS, PRODUCT SPECIFICATIONS AND DATA ARE SUBJECT TO CHANGE WITHOUT NOTICE.

Vishay Precision Group, Inc., its affiliates, agents, and employees, and all persons acting on its or their behalf (collectively, "Vishay Precision Group"), disclaim any and all liability for any errors, inaccuracies or incompleteness contained herein or in any other disclosure relating to any product.

The product specifications do not expand or otherwise modify Vishay Precision Group's terms and conditions of purchase, including but not limited to, the warranty expressed therein.

Vishay Precision Group makes no warranty, representation or guarantee other than as set forth in the terms and conditions of purchase. **To the maximum extent permitted by applicable law, Vishay Precision Group disclaims (i) any and all liability arising out of the application or use of any product, (ii) any and all liability, including without limitation special, consequential or incidental damages, and (iii) any and all implied warranties, including warranties of fitness for particular purpose, non-infringement and merchantability.**

Information provided in datasheets and/or specifications may vary from actual results in different applications and performance may vary over time. Statements regarding the suitability of products for certain types of applications are based on Vishay Precision Group's knowledge of typical requirements that are often placed on Vishay Precision Group products. It is the customer's responsibility to validate that a particular product with the properties described in the product specification is suitable for use in a particular application.

No license, express, implied, or otherwise, to any intellectual property rights is granted by this document, or by any conduct of Vishay Precision Group.

The products shown herein are not designed for use in life-saving or life-sustaining applications unless otherwise expressly indicated. Customers using or selling Vishay Precision Group products not expressly indicated for use in such applications do so entirely at their own risk and agree to fully indemnify Vishay Precision Group for any damages arising or resulting from such use or sale. Please contact authorized Vishay Precision Group personnel to obtain written terms and conditions regarding products designed for such applications.

Product names and markings noted herein may be trademarks of their respective owners.